

**(a) Typical layout of a coarse sediment trap**

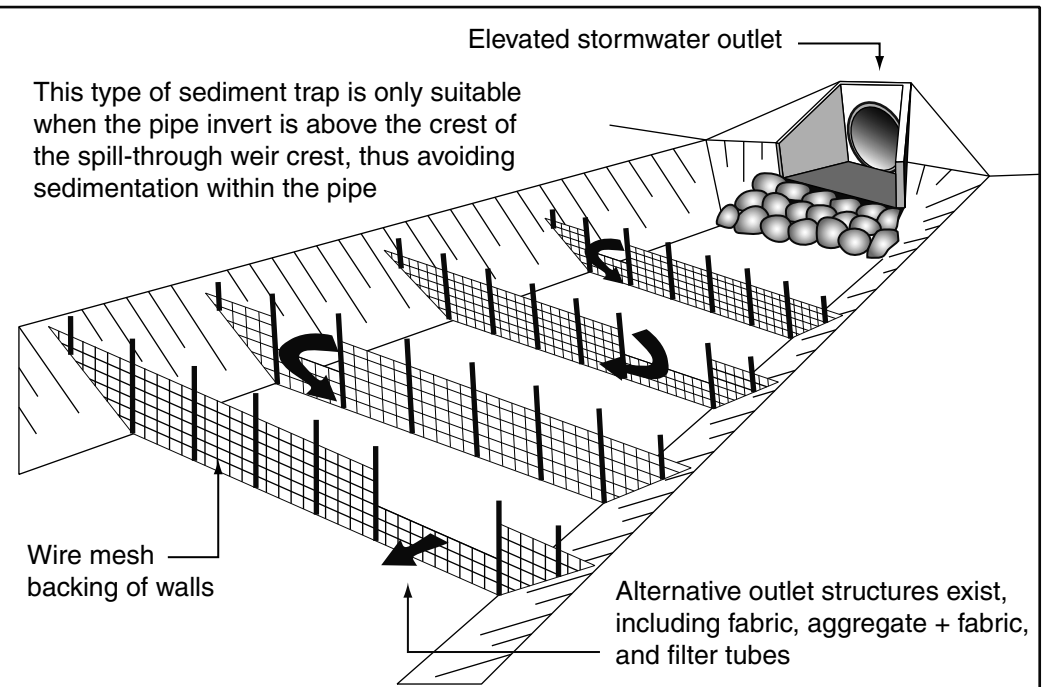

**(b) Coarse sediment trap located at pipe outlet**

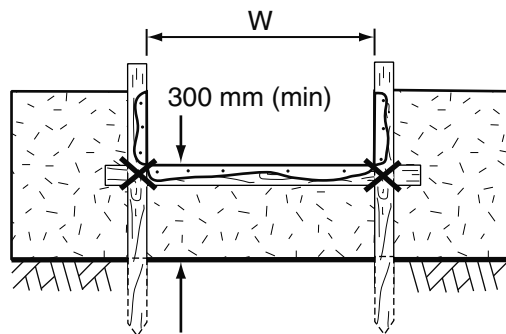

**(c) Spill-through weir**

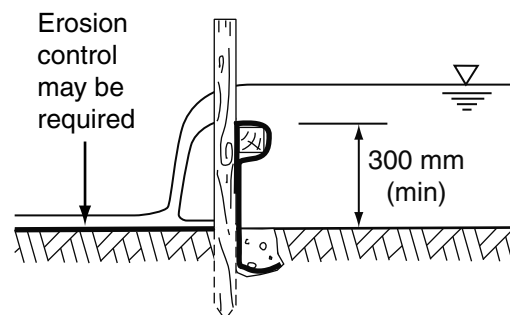

**(d) Spill-through weir**

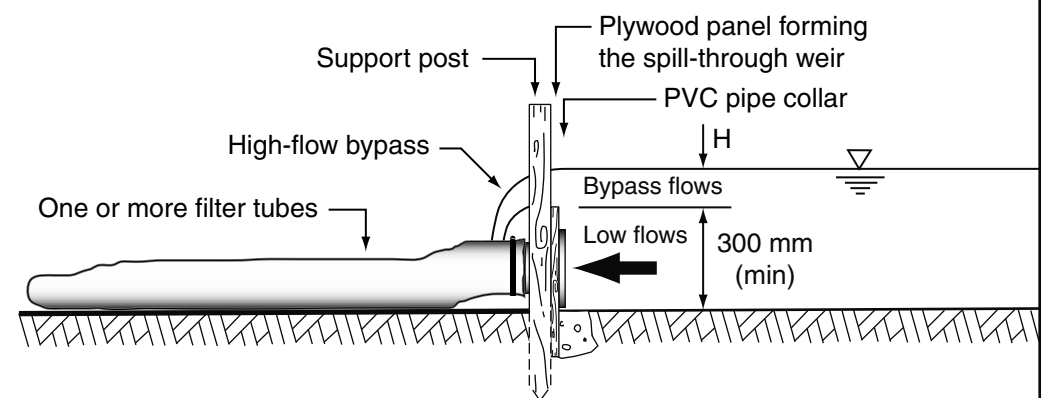

**(e) Alternative outlet structure incorporating a filter tube**

Drawn: GMW	Date: Dec-09	Coarse Sediment Trap	CST-01
---------------	-----------------	----------------------	--------