

# Sediment Fence

## SEDIMENT CONTROL TECHNIQUE

Type 1 System		Sheet Flow	✓	Sandy Soils	✓
Type 2 System		Concentrated Flow	[1]	Clayey Soils	[2]
Type 3 System	✓	Supplementary Trap		Dispersive Soils	

[1] Not recommended in areas of concentrated flow. Refer to *U-Shaped Sediment Traps*.

[2] Very limited capture of fine clay particles, but still useful for trapping sand and silt.

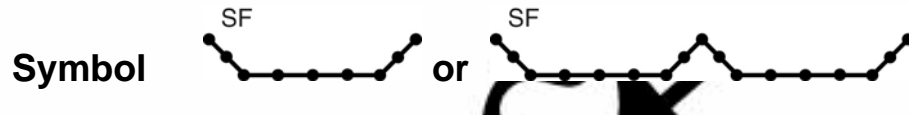

Photo 1 – Installation of a sediment fence



Photo 2 – Sediment fence located down-slope of multi-dwelling building site

### Key Principles

1. Primarily used to collect sediment particles suspended in runoff water. Sediment particles are trapped by the fabric, and water passes through the fence.
2. Treatment is primarily achieved through sedimentation. The secondary function of the fabric, if at all, is to filter out fine sediment particles.
3. Critical to the effectiveness of a sediment fence is the installation. The length of the fence is maximised.
4. The key performance objective can be achieved by installing a sediment fence (the length of the fence).

### Design Information

Maximum recommended concentrated flow of around 100 litres per second per metre of fence. The fence should be appropriately braced.

Maximum drainage area of around 1000 square metres of fence.

Maximum length of slope draining to any point along the fence should not exceed 100 metres.

Table 1 provides the recommended **maximum** slope length up-slope of a sediment fence.

**Table 1 – Recommended maximum slope length up-slope of a sediment fence on non-vegetated slopes<sup>[1]</sup>**

Batter slope			Horizontal spacing (m)	Vertical spacing (m)
Percentage	Degrees	(H):(V)		
1%	0.57	100:1		
2%	1.15	50:1		
4%	2.29	25:1		
6%	3.43	16.7:1		
8%	4.57	12.5:1		
10%	5.71	10:1		
15%	8.53	6.67:1		
20%	11.3	5:1		
25%	14.0	4:1		
30%	16.7	3.33:1		
40%	21.8	2.5:1		
50%	26.6	2:1		

[1] Maximum recommended spacings based on minimising the risk of rill erosion on low to moderately erodible soil. In areas of poor quality soil, the slope length may need to be reduced.

[2] Recommended maximum slope length above a sediment fence (10m)

The maximum slope lengths presented in Table 1 for land slopes steeper than 2% may be represented by Equation 1.

$$\text{Maximum horizontal slope length (m)} = \frac{10}{\text{Slope (\%)}} \quad (\text{Eqn 1})$$

The allowable flow rate per meter length of sediment fence should, wherever possible, be determined from actual fabric testing. However, the actual flow rate at any point in time will depend on the degree of sediment blockage of the fabric.

In the absence of testing data, preliminary design flow rates may be obtained from Table 2.

**Table 2 – Preliminary design flow rates for sediment fence fabric<sup>[1]</sup>**

Pond depth up-slope of fence (m)	Design flow rate (L/s/m)	
	Woven fabrics	Composite fabrics
0.2		
0.4		
0.6		
0.8		

[1] The above flow rates are based on simplified test results that may not extrapolate well to actual field conditions. All flow rates are based on an assumed 50% sediment blockage of the fabric.

**Technical Note:**

Australian Standards indicate that the flow rate through geotextiles for a given hydraulic head may be determined by extrapolating the measured flow rate at a hydraulic head of 100mm. Such a practice is **not** appropriate for application to woven fabrics such as sediment fence fabric. Hydraulic performance must be determined by appropriate physical testing at or above the required hydraulic head.

**(a) Choice of fabric**

Woven fabrics (

are generally preferred on small soil disturbances such as building sites, or when the sediment fence is the last line of defence prior to the runoff entering a water body.

Table 3 provides guidance on the selection of the preferred sediment fence fabric.

**Table 3 – Preferred use of sediment fabrics**

Fabric type	Preferred conditions of use
Woven fabrics	•
Composite non-woven fabrics with a woven backing	•

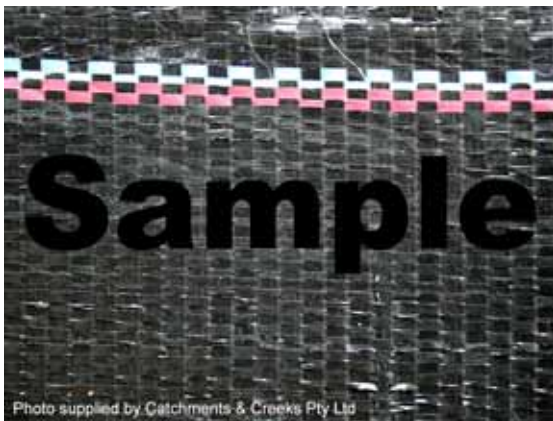

**Photo 3 – Woven sediment fence**



**Photo 4 – Composite sediment fence (not preferred)**

Composite fabrics (incorporating a non-woven fabric with woven fabric backing, typically have a higher flow rate (when first installed) due to the additional needle punching required to 'sew' the two fabrics together.

Composite fabrics are installed with the woven fabric on the down-slope side of the fence.



**Photo 5 – Composite sediment fence (woven backing on down-slope side)**



**Photo 6 – Composite sediment fence (non-woven backing on down-slope side)**

Sediment fence fabric must be manufactured from either woven fabric, or a non-woven geotextile reinforced with a mesh.

Table 4 provides the recommended material properties of woven fabrics.

**Table 4 – Recommended woven sediment fence material property requirements**

Material property	Test method	Units	Typical value
Flow rate	AS 3706.9	L/s/m <sup>2</sup> (under 100 mm head)	
Wide strip tensile strength	AS 3706.2	kN/m	
Pore size (EOS) (O <sub>95</sub> )	AS 3706.7	mm x 10 <sup>-3</sup>	
Mass per unit area	AS 3706.1	gsm	
UV resistance	AS 3706.11	% retained (672 hours)	
Width	–	m	

Table 5 provides the recommended material properties of composite fabrics.

**Table 5 – Recommended composite sediment fence material property requirements**

Material property	Test method	Units	Typical value
Flow rate	AS 3706.9	L/s/m <sup>2</sup> (under 100 mm head)	
Wide strip tensile strength	AS 3706.2	kN/m	
Pore size (EOS) (O <sub>95</sub> )	AS 3706.7	mm x 10 <sup>-3</sup>	
Mass per unit area	AS 3706.1	gsm	
UV resistance	AS 3706.11	% retained (672 hours)	
Width	–	mm	

**(b) Location of a sediment fence**

Wherever practical, the sediment fence should be installed along the contour, thus maintaining sheet flow

the fence is located along the contour, the use of regular returns is still recommended (Figure 1).

The maximum spacing of fence 'returns' should be along the contour, or 5 to 10m (depending on slope) if located at an angle to the contour (Figure 2).

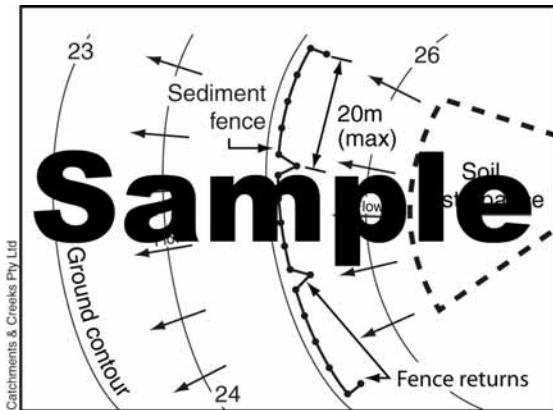

**Figure 1 – Fence installed along the contour**

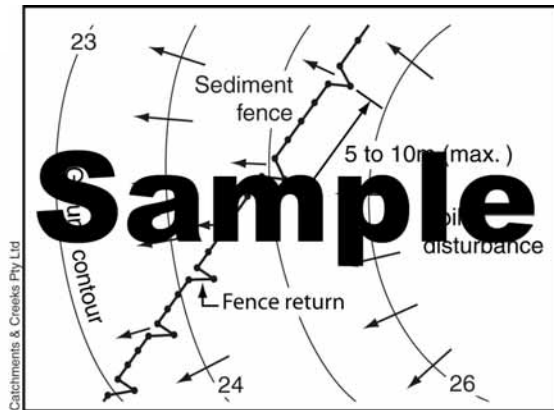

**Figure 2 – Fence install down a slope**

Wherever practical, allow at least between sediment fence and the toe of a fill slope or stockpile (Figure 3).

A double sediment fence (Figure 4, Photo 8), or sediment fence with up-slope straw bale (Photo 7) can be used to reduce risk of shifting fill damaging overall sediment trap.

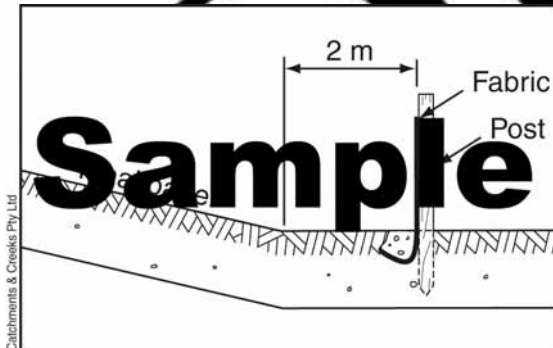

**Figure 3 – Fence installation at base of slope**

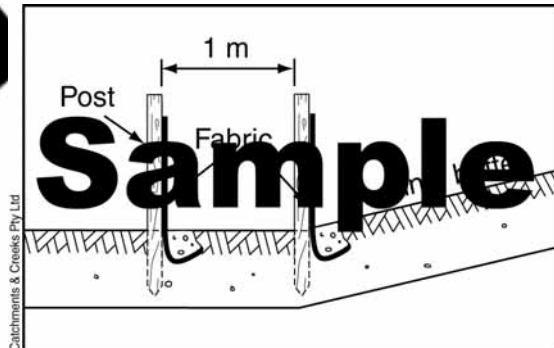

**Figure 4 – Double sediment fence installed at the based of a fill slope**



**Photo 7 –**



**Photo 8 –**

**(c) Installation of a sediment fence**

At least 300mm of fabric

(Photo 15), but **not** earth.

Straw

removal).

Alternatively, a small trench may be formed along the contour, up-slope of the fence.

Both ends of the fence should be around the ends of the fence (Figure 5, Photo 21). risk of flow bypassing

Support posts should be spaced no greater than 3m if supported by a top support wire or weir  
The recommended maximum spacing of support posts is provided in Table 6.

**Table 6 – Maximum spacing of support post**

Maximum post spacing	Installation condition
	No support wire or backing mesh.
	Support weir attached along top of the fabric at 3 m intervals. Wire mesh or PVC safety mesh backing.

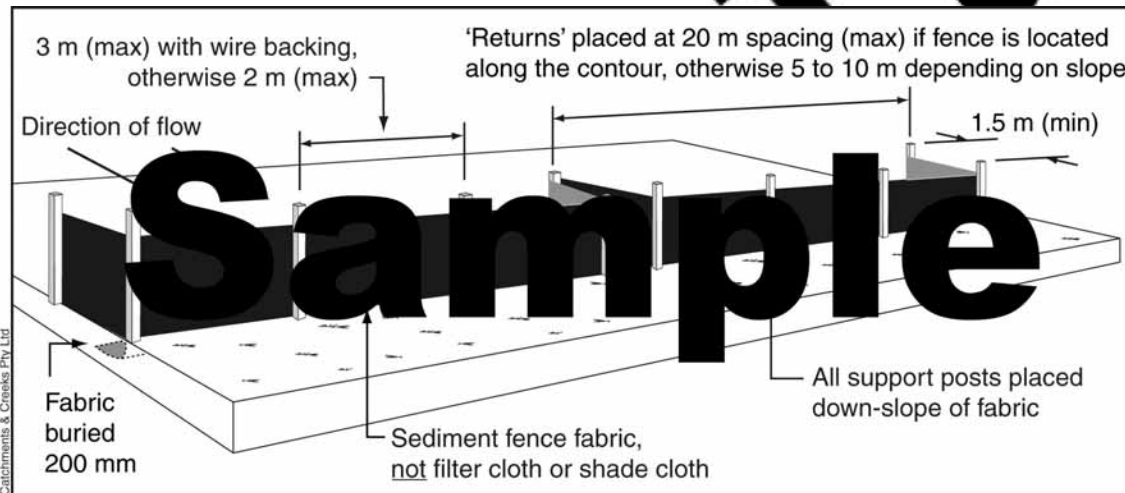

**Figure 5 – Typical installation of a sediment fence**

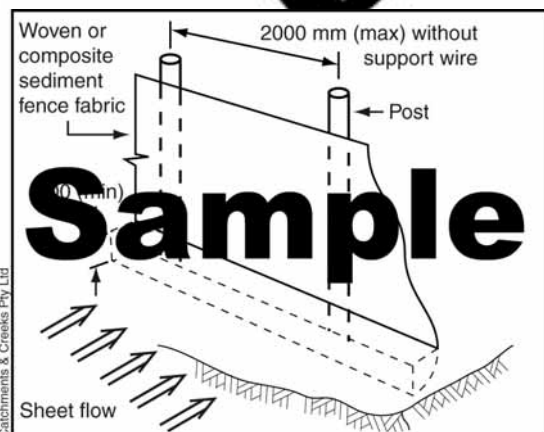

**Figure 6 – Installation of a sediment fence without wire backing**

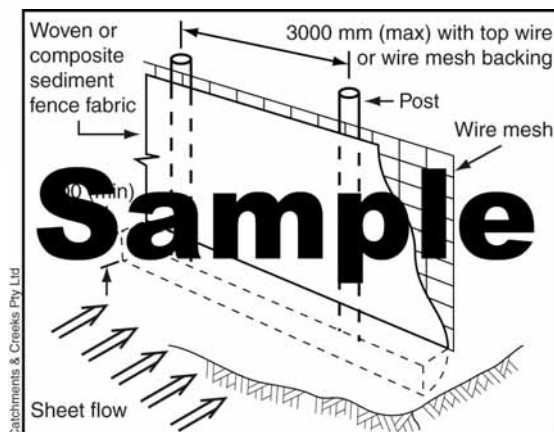

**Figure 7 – Installation of a sediment fence with top wire support**

Wherever possible, construct the sediment fence from a continuous roll. To join fabric either attach each end to individual stakes (Figure 10), holding the stakes together, rotate the stakes 180 degrees, then drive the two stakes into the ground; or overlap the fabric to the next adjacent support post (Figure 11).

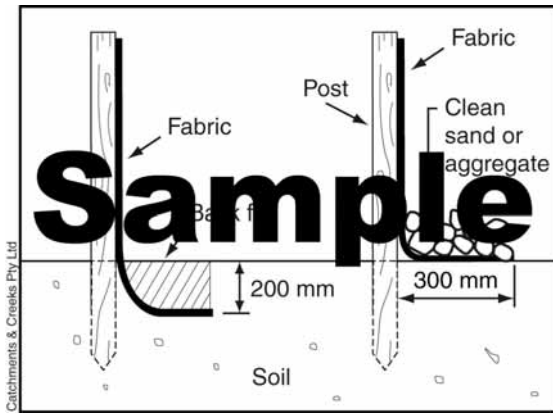

Figure 8 – Anchoring the fabric

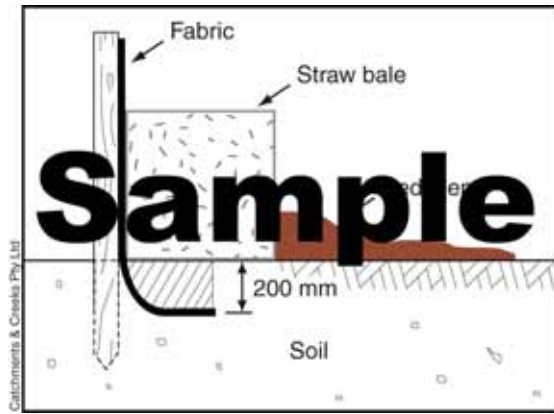

Figure 9 – Use of straw bales as a fabric-sediment separator

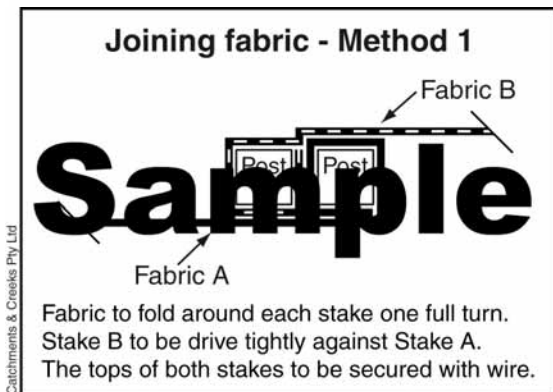

Figure 10 – Joining fabric (Option 1)

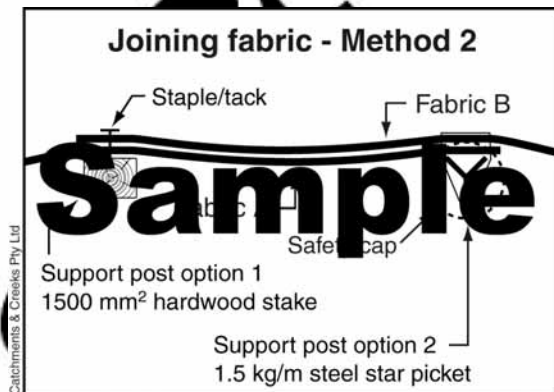

Figure 11 – Overlapping fabric (Option 2)



Photo 9 –



Photo 10 –



Photo 11 –



Photo 12 –



Photo 13 –



Photo 14 –



Photo 15 –



Photo 16 –



Photo 17 –



Photo 18 –



Photo 19 –



Photo 20 –



Photo 21 –



Photo 22 –



Photo 23 – Filtration with wire mesh



Photo 24 –



Photo 25 –



Photo 26 –



Photo 27 –



Photo 28 –



Photo 29 –



Photo 30 –



Photo 31 –



Photo 32 –



Photo 33 –



Photo 34 –



Photo 35 –



Photo 36 –

**(d) Use of spill-through weirs**

Where appropriate, spill-through weirs can be installed into the fence to reduce hydraulic pressure and reduce the risk of hydraulic failure.

On long fences located in high rainfall areas

100m of fence.

The required width (W) of the spill-through weir depends on the nominated design flow rate. The weir flow equation for a rectangular spill-through weir is provided below as Equation 2, as well as being tabulated in Table 7.

(Eqn 2)

where: Q = Design flow rate (usually 0.5 times the 1 in 1 year ARI peak discharge) [m<sup>3</sup>/s]

W = Weir width [m]

H = Hydraulic head = height of upstream water level above weir crest [m]

**Table 7 – Flow rates passing over a spill-through weir (m<sup>3</sup>/s)**

Hydraulic head, H (m)	Spill-through weir width (m)								
	0.3	0.5	1.0	1.5	2.0	2.5	3.0	3.5	4.5
0.10									
0.15									
0.20									
0.25									
0.30									
0.35									
0.40									

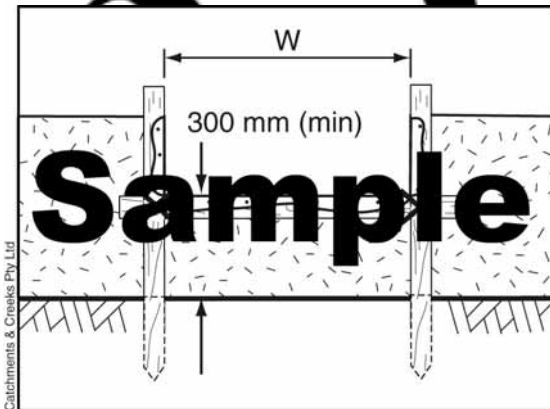

**Figure 12 – Spill-through weir profile**

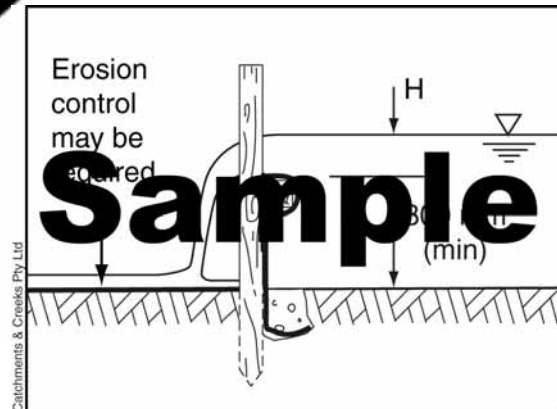

**Figure 13 – Side profile of a spill-through weir**



Photo 37 –



Photo 38 –



Photo 39 – through weir with slope aggregate filter



Photo 40 –

If large sediment flows are expected then a coarse *Sediment Trap* can be used as an outlet structure for a sediment fence as shown in Figure 14. However, in most circumstances, a more elaborate system would be required such as a Type 1 or Type 2 sediment trap.

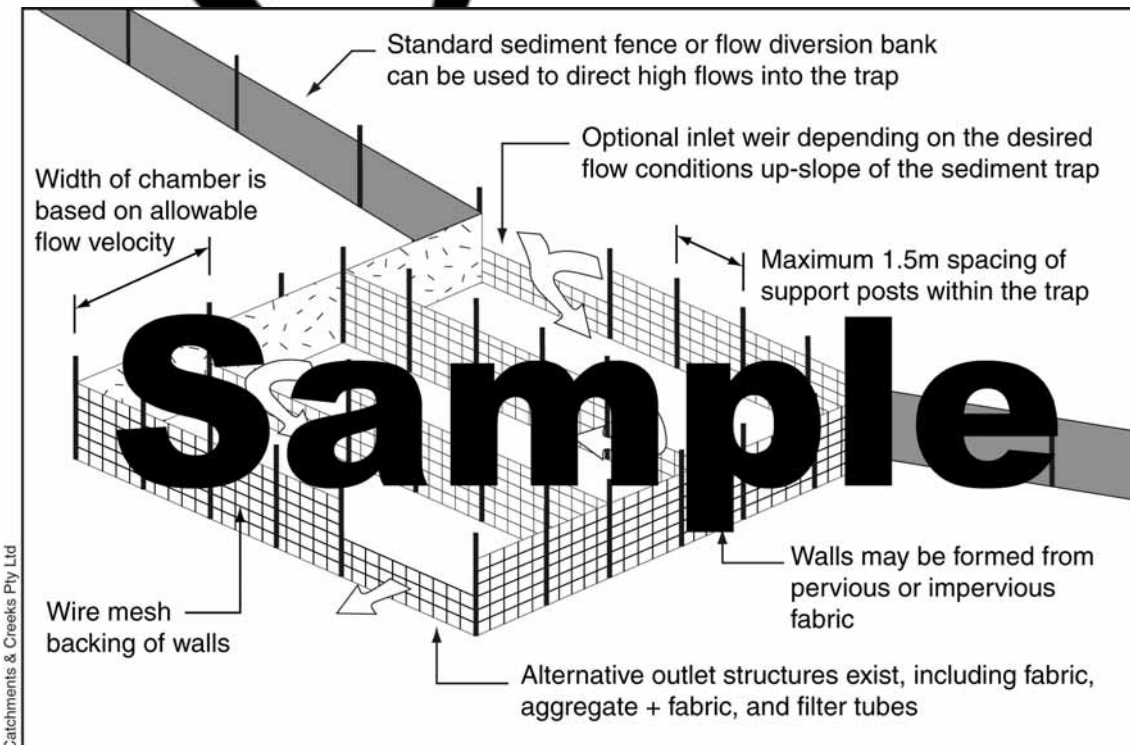

Figure 14 – Coarse sediment trap outlet structure

## Description

A sediment fence consists of specially designed and manufactured woven fabric attached to support posts. The typical height of the fence is around 600 to 700mm.

Most sediment fences are self-supporting; however, in appropriate circumstances the fence may be attached to an existing porous structure such as a fence.

The fabric may be manufactured from either woven fabric, or a composite of woven and non-woven fabrics. The incorporation of a woven fabric is essential for the control of water flow needed to allow adequate temporary ponding up-slope of the fence.

## Purpose

Used as a Type 3 sediment trap on small catchments, or as a supplement to Type 1 or 2 sediment traps on large catchments.

Best used to treat 'sheet' runoff from disturbed surfaces.

## Limitations

Though often referred to as 'silt fence', these Type 3 sediment traps have little impact on fine silts ( $< 0.075\text{mm}$ ).

A sediment fence in its standard installation is only suitable for the treatment of 'sheet' flows. If concentrated flow exist, such as in a minor drain, then a *U-Shaped Sediment Trap*, or other more appropriate sediment trap should be used.

Drainage area limited to 0.6ha per 100m of fence, and a maximum fence length of 60m.

Most fabrics have an effective service life of around 6 months (check with specific manufacturer or distributor).

## Advantages

Reasonably easy to install.

Has the ability to controls sediment runoff close to the source of the erosion.

A highly visible sediment control measure.

## Disadvantages

Time-consuming to install, which often results in poor installation.

Easily damaged by construction equipment and shifting earth (Photos 31 & 32).

Can cause the concentration of stormwater runoff if poorly located, or installed.

Often poorly installed and maintained.

Sediment fences are one of the most missed used sediment control devices, usually because they are either not installed in appropriate locations, or are installed in a manner that does not allow adequately water ponding up-slope of the fences.

## Common Problems

If not installed along the contour, a sediment fence can result in flows being deflected along the fence (Photo 29).

If the ends of the fence are not turned up the slope, water and sediment can pass around the end of the fence (Photo 30).

If gaps occur in the fence (Photos 19 & 20), then water is prevented from ponding up-slope of the fence, thus sedimentation does not occur.

Appropriate silt-through screens may not have been installed in large catchments or areas of high rainfall, thus increasing the risk of flow damage to the fence.

Excessive spacing between support posts is a very common problem. In extreme cases this can result in the fabric sagging close to the ground.

The fabric may not be adequately connected to the support posts or backing wire.

The bottom of the fabric may not be adequately buried into the ground or under a suitable layer of sand or aggregate. If such fences are subjected to significant storms, the bottom of the fence can 'blow-out' causing erosion down-slope of the fence (Photo 33).

## Special Requirements

Woven fabrics are generally preferred on large sites when the service life is expected to extend over several storm events. Composite fabrics are generally preferred on small soil disturbances such a building sites, or when the sediment fence is the last line of defence prior to the runoff entering a water body.

Ideally, the sediment fence should be installed along the contour, thus maintaining sheet flow conditions across fence. If located across the contour, the fence should be installed regular 'returns' to avoid water concentrating along the fence.

At least 300mm of fabric must be buried in either a 200mm trench, or under a continuous, 100mm high layer of sand or aggregate, but not earth.

Straw bales may be placed up-slope of the fence to retain bulk sediment away from the fabric, thus improving the ease of sediment removal. Alternatively, a small trench may be formed along the contour, up-slope of the fence. However, in all cases the aim should be to investigate and minimise high sediment flows so that such measures becomes the exception, not the rule!

Where appropriate, spill-through weirs can be installed into the fence to reduce hydraulic pressure and reduce the risk of hydraulic failure.

### Location

Install along the contour wherever possible.

Allow at least 4.5m between the fence and single-story buildings; 7.5m between the fence and multiple-story buildings; and at least 2m between the fence and the toe of a fill slope or stockpile.

### Site Inspection

Ensure the sediment fence will adequately pond water up-slope of the fence.

Ensure the fabric adequately buried.

Check the spacing of support posts.

Check for excessive sediment deposition.

Investigate the source of excessive sediment deposits.

Ensure the appropriate selection of fabric (i.e. woven or composite).

Check for damage to the fabric.

Check for erosion down-slope of any spill-through weirs.

Ensure the fence is not concentrating or diverting flows in an undesirable manner.

### Materials

- Fabric: polypropylene, polyamide, nylon, polyester, or polyethylene woven or non-woven fabric, at least 700mm in width and a minimum unit weight of 140g/m. All fabrics to contain ultraviolet inhibitors and stabilisers to provide a minimum of 6 months of useable construction life (ultraviolet stability exceeding 70%).
- Fabric reinforcement: wire or steel mesh minimum 14-gauge with a maximum mesh spacing of 200mm.
- Support posts/stakes: 1500mm<sup>2</sup> (min) hardwood, 2500mm<sup>2</sup> (min) softwood, or 1.5kg/m (min) steel star pickets suitable for attaching fabric.

### Installation

1. Refer to approved plans for location, extent, and required type of fabric (if specified). If there are questions or problems with the location, extent, fabric type, or method of installation contact the engineer or responsible on-site officer for assistance.
2. To the maximum degree practical, and where the plans allow, ensure the fence is located:
  - (i) totally within the property boundaries;
  - (ii) along a line of constant elevation where practical;
  - (iii) at least 2m from the toe of any filling operations that may result in shifting soil damaging the fence.
3. Install 'returns' within the fence at maximum 5m intervals. The fence is installed along the contour, or 5 to 10m maximum spacing (depending on slope) if the fence is installed at an angle to the contour. The 'returns' shall consist of either:
  - (i) V-shaped section extending at least 1.5m up the slope; or
  - (ii) sandbag or rock/aggregate check dam a minimum 1/3 and maximum 1/2 fence height, and extending at least 1.5m up the slope.
4. Ensure the extreme ends of the fence are turned up the slope at least 1.5m, or as necessary, to minimise water bypassing around the fence.
5. Ensure the sediment fence is installed in a manner that avoids the concentration of flow along the fence, and the undesirable discharge of water around the ends of the fence.
6. If the sediment fence is to be installed along the edge of existing trees, ensure care is taken to protect the trees and their root systems during installation of the fence. Do not attach the fabric to the trees.
7. Unless directed by the site supervisor or the approved plans, excavate a 200mm wide by 200mm deep trench along the proposed fence line, placing the excavated material on the up-slope side of the trench.

8. Along the lower side of the trench, appropriately secure the stakes into the ground spaced no greater than 3m if supported by a top support wire or weir mesh backing, otherwise no greater than 2m.
9. If specified, securely attach the support wire or mesh to the up-slope side of the stakes with the mesh extending at least 200mm into the excavated trench. Ensure the mesh and fabric is attached to the up-slope side of the stakes even when directing a fence around a corner or sharp change-of-direction.
10. Wherever possible, construct the sediment fence from a continuous roll of fabric. To join fabric either:
  - (i) attach each end to two overlapping stakes with the fabric folding around the associated stake one turn, and with the two stakes tied together with wire (Method 1); or
  - (ii) overlap the fabric to the next adjacent support post (Method 2).
11. Securely attach the fabric to the support posts using 25 x 12.5mm staples, or the wire at maximum 150mm spacing.
12. Securely attach the fabric to the support wire/mesh (if any) at maximum spacing of 1m.
13. Ensure the completed sediment fence is at least 450mm but not more than 700mm high. If a spill-through weir is installed, ensure the crest of the weir is at least 300mm above ground level.
14. Backfill the trench and tamp the fill to firmly anchor the bottom of the fabric and mesh to prevent water from flowing under the fence.

***Additional requirements for the installation of a spill-through weir***

1. Locate the spill-through weir such that the weir crest will be lower than the ground level at each end of the fence.
2. Ensure the crest of the spill-through weir is at least 300mm the ground elevation.
3. Securely tie a horizontal cross member (weir) to the adjacent support posts. Cut the fabric down the side of the posts and fold the fabric over the cross member and appropriately secure the fabric.

4. Install a suitable splash pad and/or chute immediately down-slope of the spill-through weir to control soil erosion and appropriately discharge the concentrated flow passing over the weir.

**Maintenance**

1. Inspect the sediment fence at least weekly and after any significant rain. Make necessary repairs immediately.
2. Repair any torn sections with a continuous piece of fabric from post to post.
3. When making repairs, always restore the system to its original configuration unless an amended layout is required or specified.
4. If the fabric is sagging between stakes, install additional support posts.
5. Remove accumulated sediment if the sediment deposit exceeds a depth of 1/3 the height of the fence.
6. Dispose of sediment in a suitable manner that will not cause an erosion or pollution hazard.
7. Replace the fabric if the service life of the existing fabric exceeds 6-months.

**Removal**

1. When disturbed areas up-slope of the sediment fence are sufficiently stabilised to restrain erosion, the fence must be removed.
2. Remove materials and collected sediment and dispose of in a suitable manner that will not cause an erosion or pollution hazard.
3. Rehabilitate/revegetate the disturbed ground as necessary to minimise the erosion hazard.