

Pipe and Culvert Inlet Sediment Traps

SEDIMENT CONTROL TECHNIQUES



Photo 1 – Pipe inlet



Photo 2 – Culvert inlet

Table 1 provides the recommended default classification of various sediment control systems suitable for sheet flow conditions.

Table 1 – Default classification of sediment control techniques^[1]

| Type 2 | Type 3 |
|---|---|
| <ul style="list-style-type: none"> • Block & Aggregate Drop Inlet Protection^[2] • Compost-Filled Filter Sock^[2] • Mesh & Aggregate Drop Inlet Protection^[2] • Rock & Aggregate Drop Inlet Protection^[2] | <ul style="list-style-type: none"> • Excavated Drop Inlet Protection • Fabric Drop Inlet Protection • Fabric Wrap Drop Inlet Sediment Trap |

[1] Classification is based on the technique being sized in accordance with best practice standards, otherwise the technique attracts a lower classification.

[2] Classification depends on design details.

Table 2 provides guidance on the selection of the best sediment control technique for various site conditions.

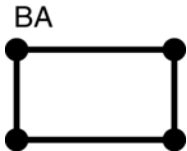
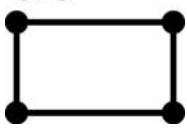

Table 2 – Selection of the preferred field (drop) inlet sediment control technique

| Location | Site condition | Technique preference |
|----------------|-------------------------------|---|
| Pipe inlets | Small diameter pipes (<600mm) | Compost-filled filter sock Sediment fence with spill-through |
| | Large diameter pipes (>600mm) | As per culvert inlets |
| Culvert inlets | Small diameter pipes (<600mm) | Compost-filled filter sock, or Filter tube dam |
| | Large diameter pipes (>600mm) | Filter tube dam |
| | As above, 2nd preference | Sediment weir with filter tubes |
| | As above, 3rd preference | Block and aggregate system, or Timber and aggregate system, or Sediment weir without filter tubes |
| | As above, 4th preference | Mesh and aggregate system with incorporated filter cloth |
| | As above, 5th preference | Rock and aggregate system |

Sediment traps at pipe and culvert inlets

Table 3 outlines the attributes of various sediment control techniques that can be used at the inlet of culverts and open stormwater pipes.

Table 3 – Sediment control techniques at the entrance to culverts and open stormwater pipes

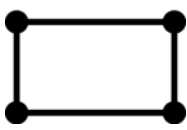
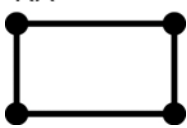
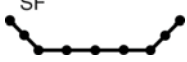
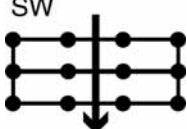
| Technique | Code | Symbol | Typical use |
|--|------|---|---|
| Block & Aggregate sediment trap | BA |  | <ul style="list-style-type: none"> Type 2 or 3 sediment trap. Small to medium catchment areas. It is usually necessary for the <i>Block and Aggregate</i> barrier to be constructed in a manner that does not block or partially block the pipe or culvert entrance. Filter cloth may be placed between the aggregate and the support blocks to improve the removal of fine sediments. Heavy, solid timber planks can be used as an alternative to concrete blocks. |
| Compost-Filled Filter Sock | CFS |  | <ul style="list-style-type: none"> For small inlets, the compost is usually contained within a larger-diameter filter sock. Techniques can include <i>Filter Socks</i> and <i>Compost Berms</i>. Large compost or mulch berms usually require too much space to be located around most field inlets. |
| Filter Tube Dam | FTD |  | <ul style="list-style-type: none"> Type 2 or 3 sediment trap. Small to medium catchments. Filter tube usually can extend into the pipe or culvert. |
| Mesh & Aggregate sediment trap | MA |  | <ul style="list-style-type: none"> Type 2 or 3 sediment trap. Small to medium catchments. Depth of ponding upstream of the inlet is governed by the height of the aggregate filter placed in front of the wire mesh. |
| Rock & Aggregate Drop Inlet Protection | RA |  | <ul style="list-style-type: none"> Type 2 or 3 sediment trap. Best used in coarse-grained (i.e. low clay) soil areas. Locations where space is not critical as these structures have a large footprint. |
| Sediment Fence (woven or non-woven) | SF |  | <ul style="list-style-type: none"> Type 3 sediment trap. Not recommended unless there is a very high expectation that flows will be very low. Not suitable for culvert inlets. |
| Sediment Weir | SW |  | <ul style="list-style-type: none"> Type 2 or 3 sediment trap. Generally stronger than a <i>Mesh & Aggregate</i> sediment trap. Best used when high flow rates are expected. Best results are achieved when filter tubes are incorporated into the weir. |

The following figures show various layouts of pipe and culvert inlet sediment traps.

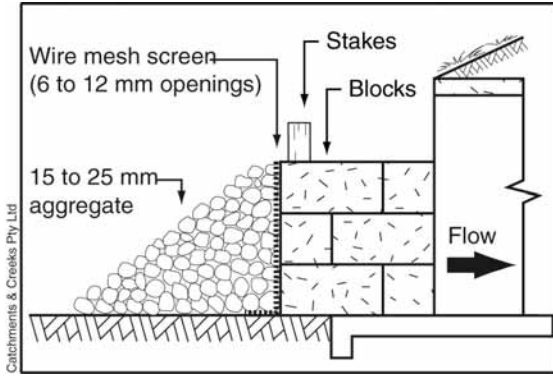

Figure 1 – Block and aggregate system

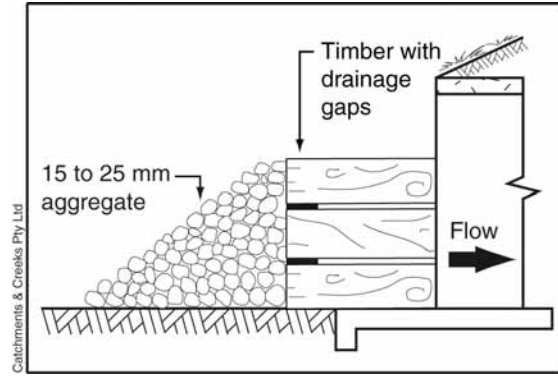

Figure 2 – Timber and aggregate system

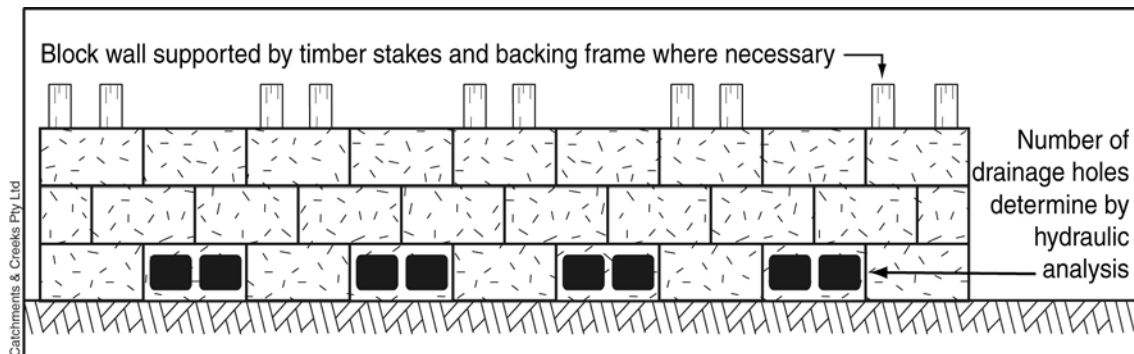

Figure 3 – Typical layout of block wall (front view without aggregate filter shown)

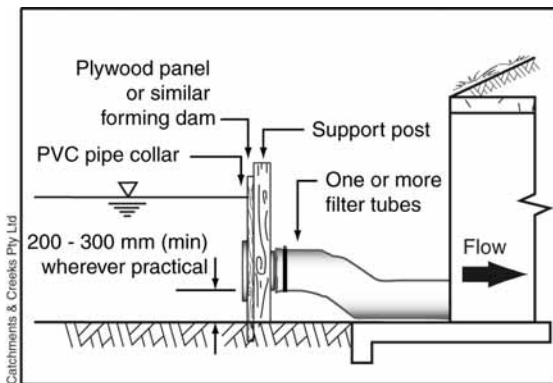

Figure 5 – Filter tube dam system

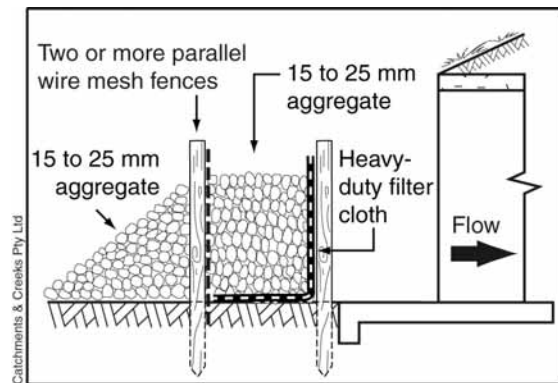

Figure 6 – Sediment weir system

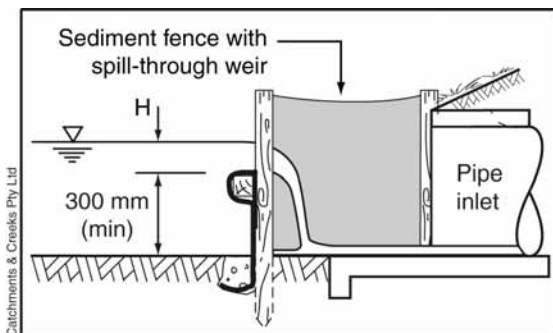

Figure 7 – Sediment fence system

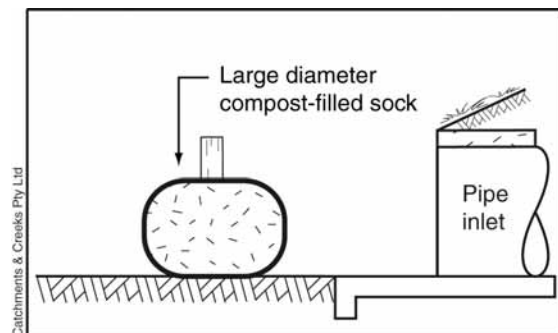

Figure 8 – Compost-filled filter sock